

Univers Revers™ Augmented Modular Glenoid System

Surgical Technique

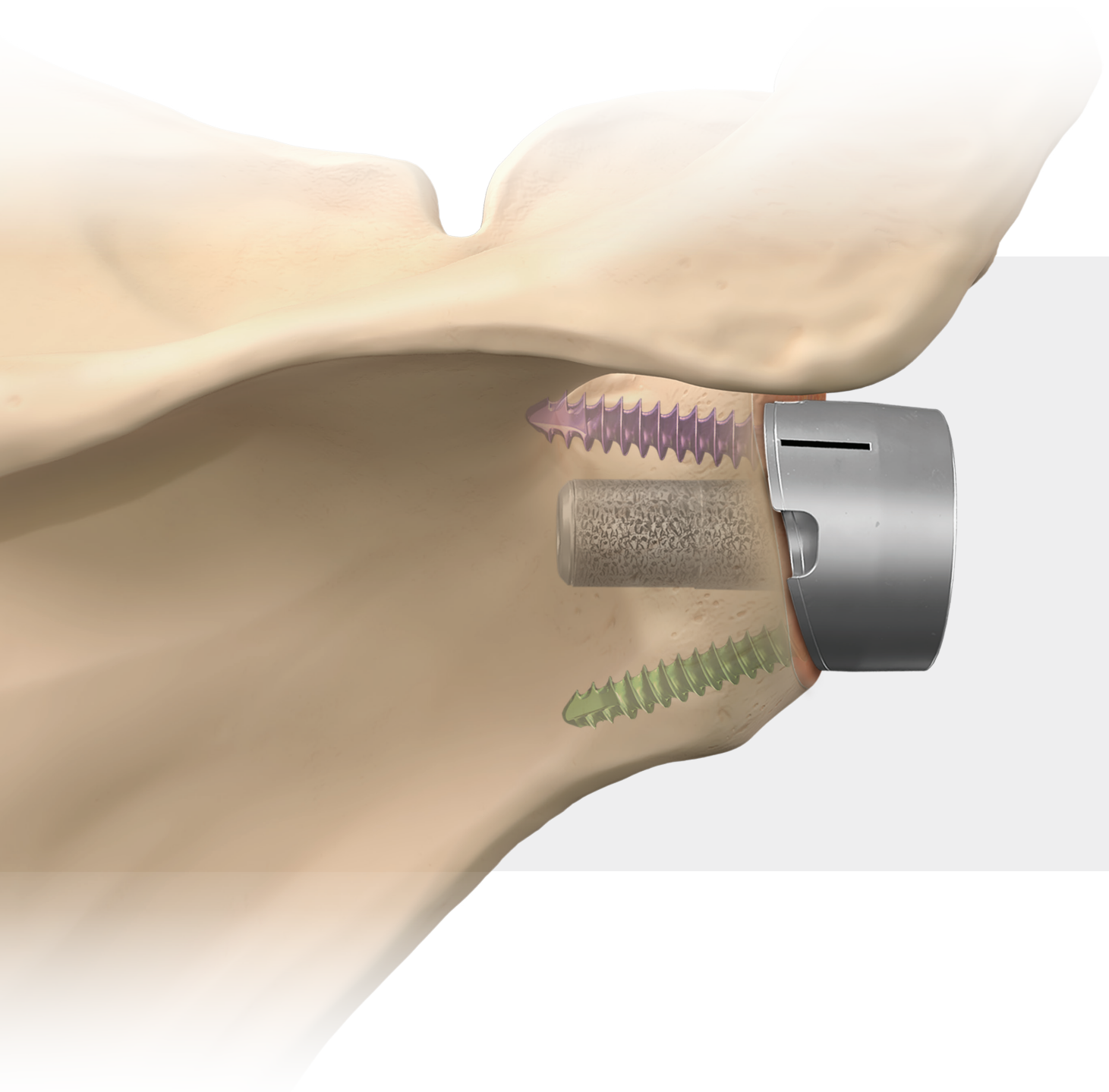

The Univers Revers Augmented Modular Glenoid System, a complementary addition to the Univers Revers system portfolio, builds upon the design concept of providing options for Helping Surgeons Treat Their Patients Better™. With the Augmented Modular Glenoid System, Arthrex has advanced this mission by providing a multitude of component choices, helping surgeons provide a tailored approach to individual patient needs. The Augmented Modular Glenoid System is designed to work only with the Univers Revers humeral components and is not cleared by the FDA for use with any other reverse shoulder arthroplasty system.

Indications

The Univers Revers Modular Glenoid System is indicated for use in a grossly rotator cuff deficient glenohumeral joint with severe arthropathy or a previously failed joint replacement with a gross rotator cuff deficiency. The patient's joint must be anatomically and structurally suited to receive the selected implant(s), and a functional deltoid muscle is necessary to use the device. The Univers Revers Modular Glenoid System is indicated for primary, fracture, or revision total shoulder replacement for the relief of pain and significant disability due to gross rotator cuff deficiency. The Univers Revers Modular Glenoid System is porous coated and is intended for cementless use with the addition of screws for fixation.

Contraindications

1. Insufficient quantity or quality of bone.
2. Blood supply limitations and previous infections, which may retard healing.
3. Foreign body sensitivity. Where material sensitivity is suspected, appropriate tests should be ordered and sensitivity ruled out prior to implantation.
4. Any active infection or blood supply limitations.
5. Conditions that tend to limit the patient's ability or willingness to restrict activities or follow directions during the healing period.
6. The use of this device may not be suitable for patients with insufficient or immature bone. The physician should carefully assess bone quality before performing orthopedic surgery. The use of this medical device and the placement of hardware or implants must not bridge, disturb or disrupt the growth plate.
7. Do not use for surgeries other than those indicated.

Glenoid Evaluation

There are two options for choosing the most appropriate implant size, shape (augmented or nonaugmented), and position:

- **Virtual Implant Positioning™ (VIP™) System**—When using the VIP system, use the measurement features within the planning tool to evaluate the need, location, and measurements of the glenoid anatomy to optimize surgical outcomes. For specific instructions on using the VIP system, please visit Arthrex.com.
- **Augmented Modular Glenoid System Instrumentation**—If not using the VIP system, the glenoid can still be evaluated to determine the severity of the bony deficit and which implant is best suited for the anatomy. Use the following steps as a guide for assessing, preparing, and implanting an Augmented Modular Glenoid System prosthesis.



Surgical Technique

Glenoid Surface Preparation

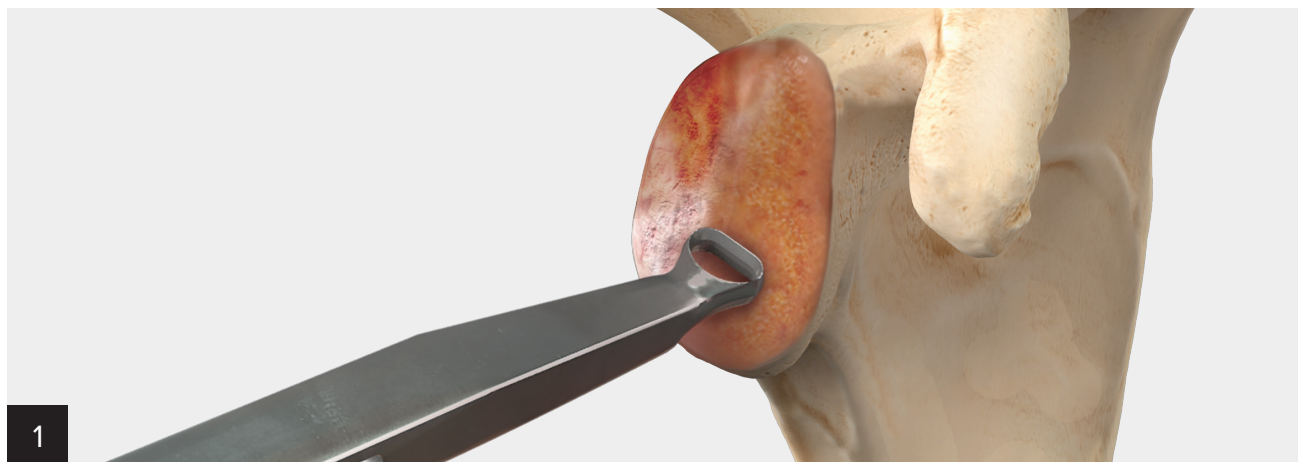

Prepare the glenoid for reaming by removing the surface cartilage. Either end of the glenoid scrapette instrument, a ring curette, or a Cobb elevator may be used for this purpose.

Glenoid Guidewire Placement

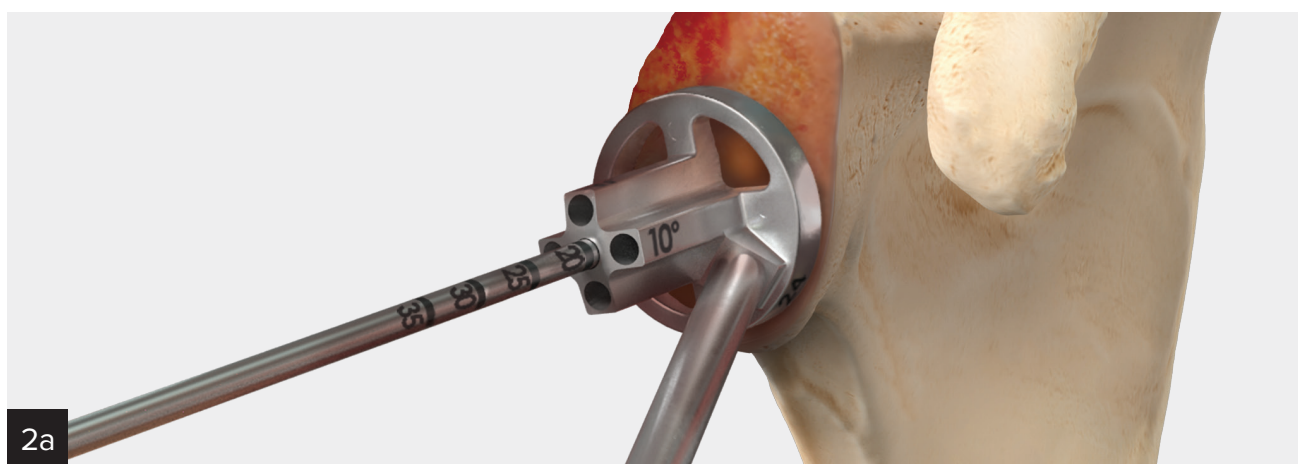

Select the appropriately sized glenoid sizer/pin guide (24 mm or 28 mm) based on the diameter of the desired glenoid baseplate. Place the pin guide onto the glenoid face and insert the 2.8 mm guidewire into the selected hole.

Drive the 2.8 mm guidewire to the desired depth within the glenoid vault. The laser etching on the guidewire may be used to estimate the length of the central post to be implanted, but a secondary depth guide should be used to verify this measurement once the glenoid face has been reamed.

Note: There are 5 holes within the pin guide. The 4 peripheral holes all orient the guidewire 10° divergent from neutral. The central hole provides a neutral guidewire trajectory.

Remove the pin guide, leaving the guidewire in place.



To assess glenosphere sizing and positioning relative to the guidewire placement, introduce the glenosphere sizing guide over the guidewire. The notches on the sides of the guide correspond to each of the glenosphere diameters available within the system.

Note: If using a Full-Wedge Augment, proceed to page 05; if using a Half-Wedge Augment, proceed to page 10.

Preparation Steps for Full-Wedge Augments

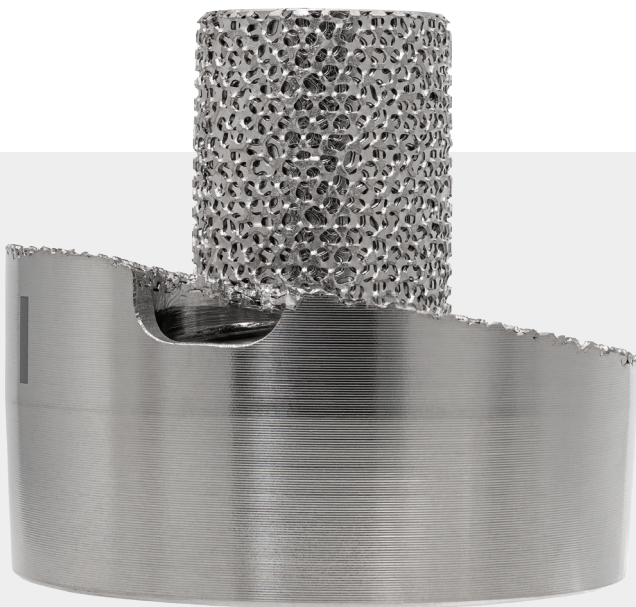

10° Full-wedge augmented baseplate

Note: The augmented portion of the baseplate may be obliquely oriented or aligned to the peripheral screw holes depending on which implant is chosen. This is an important consideration in planning for the augment orientation.

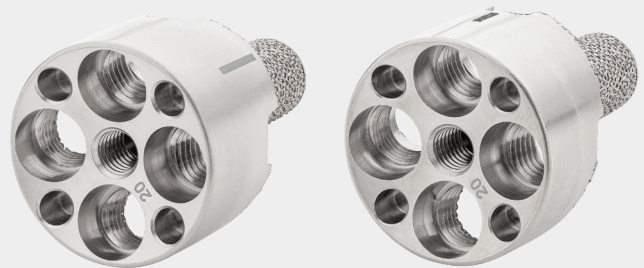

(a)

Orientation of the oblique augment (a)

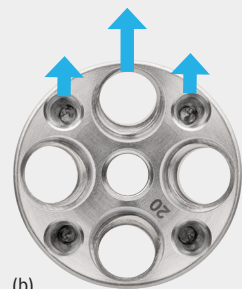

(b)

Orientation of the standard augment (b)

Preparation Steps for Full-Wedge Augments



Assessment of Glenoid Defect

Attach the appropriate augment sizer onto the modular handle.

Each augment sizer is color-coded by augment angle (ivory: 10° full-wedge; black: 20° full-wedge). Place the sizer assembly over the guidewire, advancing until the sizer touches the glenoid face. The larger arm of the sizer should rest within the area where the bony deficit is greatest. If the arm is unable to touch the glenoid surface within the defect, it may be necessary to evaluate the defect using a sizer with an increased angle.

Once the area containing the greatest bony defect has been identified with the augment sizer, mark the location with a marking pen or electrocautery device. A mark 180° opposite of this location should also be made, as both of these marks are used to assist in orienting the reamer during the glenoid reaming process.

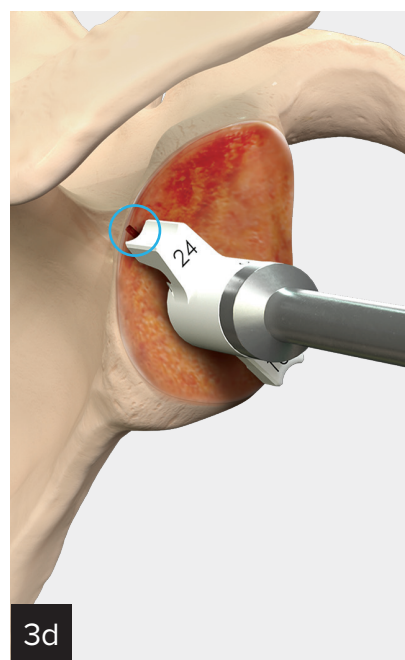
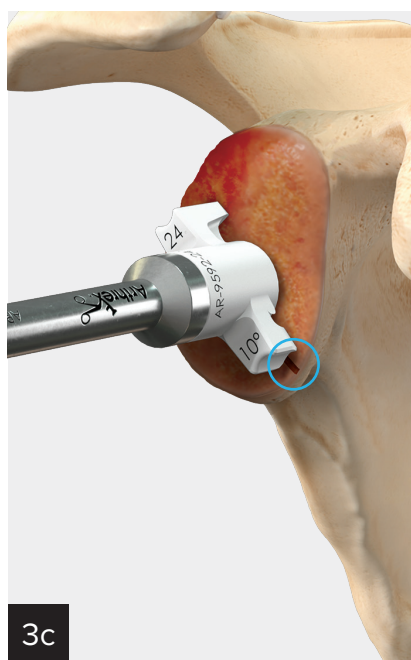
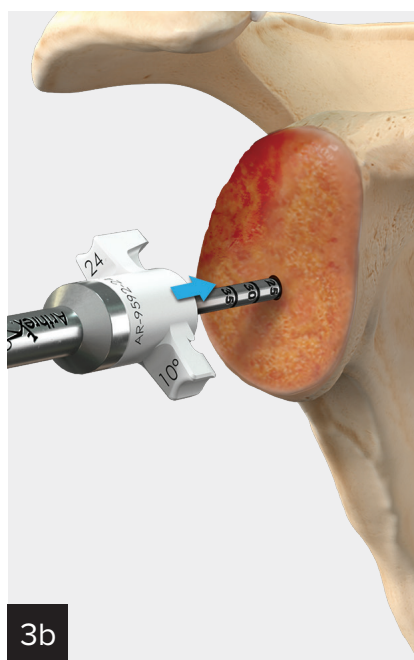

Glenoid Reaming

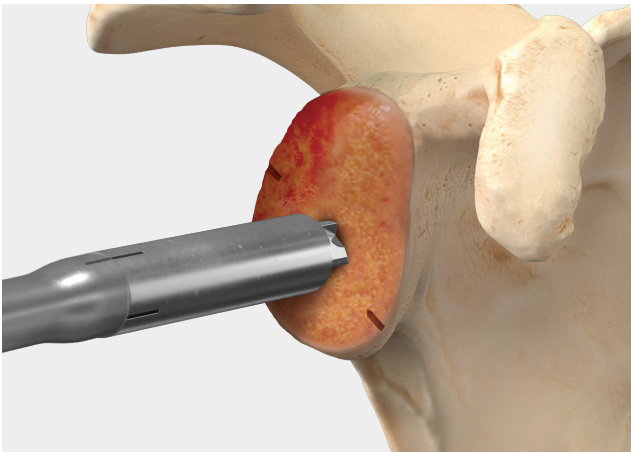

Optional Step

For cases in which sclerotic bone is present, the pilot drill can be used prior to reaming. This drill clears the bone that closely surrounds the guidewire, and helps facilitate more efficient reaming of the glenoid surface.

If using the pilot drill, attach the drill to the modular reamer shaft from the Modular Glenoid System instrument set. Introduce the drill over the guidewire and advance the drill until the collar is flush with the glenoid face.

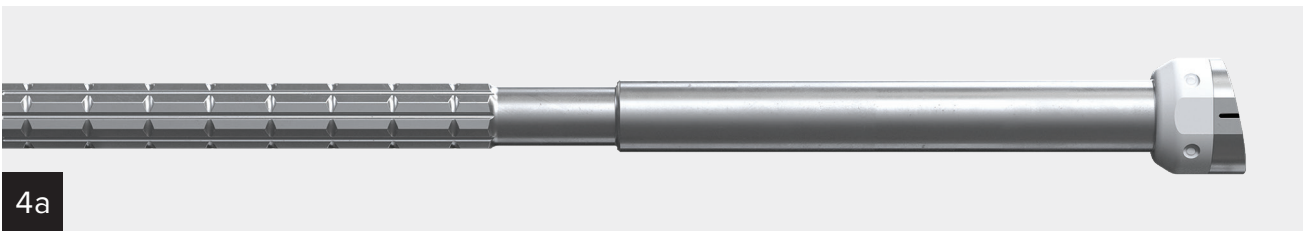

4a

Select the angled reaming sleeve that matches the full augment sizer used in the previous step. The outer sleeves are color-coded and it is important to verify that the color of the outer sleeve matches the color of the augment sizer.

Note: Refer to the reference chart below for the appropriately sized disposable angled reamer for each Augmented Modular Glenoid System full-wedge implant.

	24 mm	28 mm
10° Full-wedge	S	M
20° Full-wedge	S	L

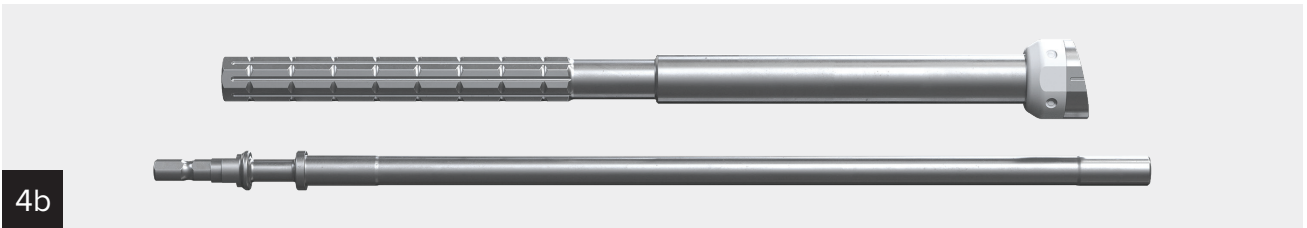

4b

Insert the inner reamer shaft through the angled reamer sleeve (a). Couple the disposable angled reamer to the inner reamer shaft (b). A tactile coupling should be felt.



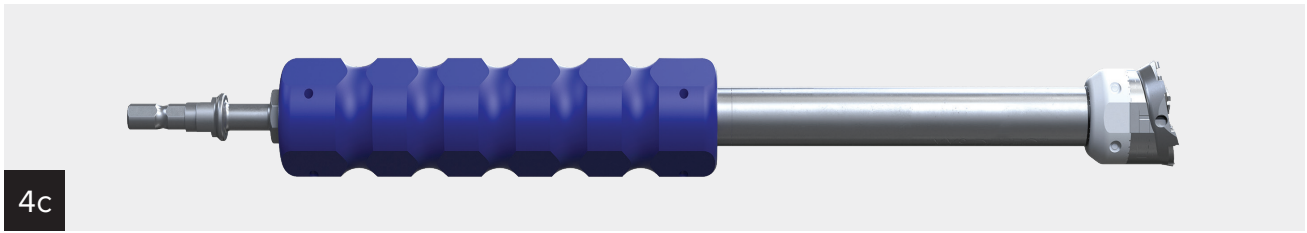

4c

Before attaching the reamer assembly to the powered hand equipment, it is recommended that the orientation sleeve be placed over the reamer sleeve to assist with rotational control while reaming.

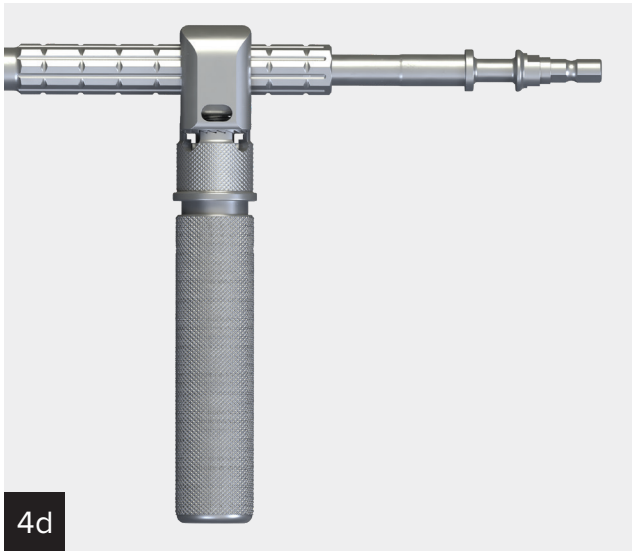

4d

Alternatively, the orientation handle can be attached to the angled reamer sleeve. If using the orientation handle, it is recommended to align the handle with the anterior dotted line on the reamer sleeve.

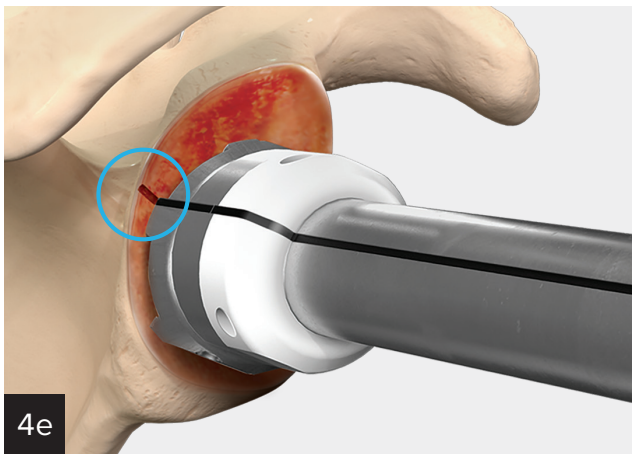

4e

Insert the angled reamer assembly over the guide pin. Rotate the reamer assembly about the pin so that the lines on the reamer shaft align to the marks that were made previously. The dotted line on the reamer shaft should be positioned opposite of the identified defect. This alignment mark may indicate the best manner for visualizing the reamer orientation during the reaming process.

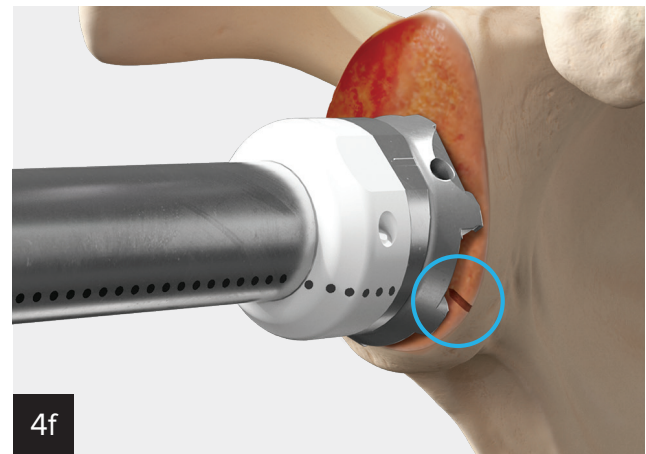

4f

Be careful to maintain alignment of the reamer to the marks on the glenoid. Continue reaming until the glenoid face has been reamed into a flat plane within the diameter of the selected reamer size.

Assessment of Reamed Surface

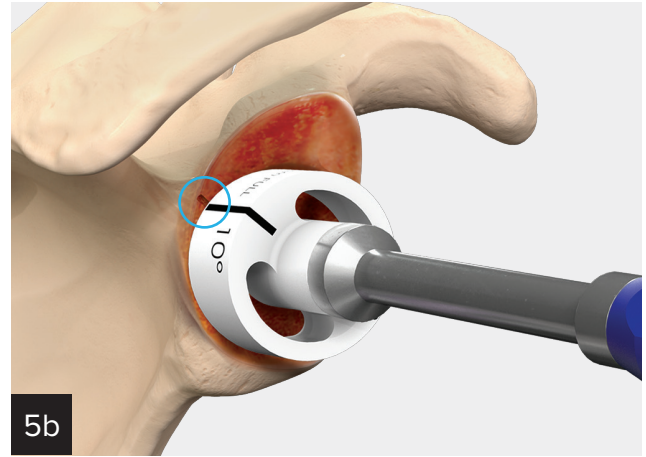
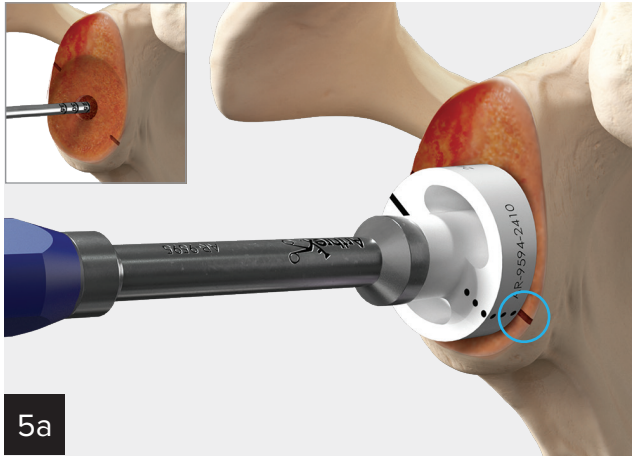

Place the augment trial matching the color and angle of the previously used instrumentation onto the modular handle. Insert the trial assembly over the guidewire and advance until the trial face is seated on the prepared glenoid surface.

Assess the fit of the trial on the glenoid. To help determine if the trial and prepared glenoid surface made congruent contact, rotate the trial clockwise and counterclockwise. If not, repeat the reaming steps in Step 4 until proper mating of the trial to glenoid surface can be achieved.

Measuring for Central Post Length

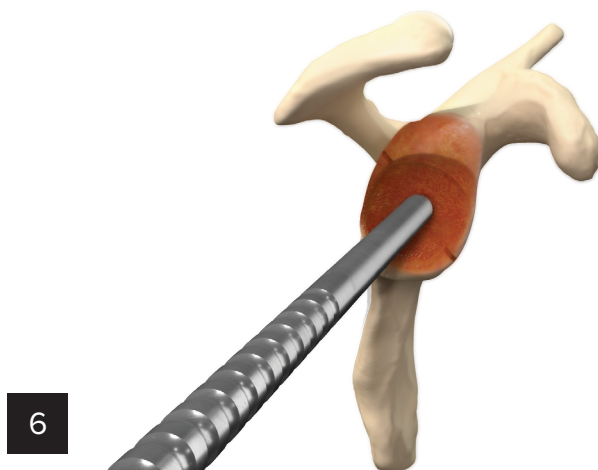

Introduce the full-wedge central post depth gauge over the guidewire.

Note: There are 2 sides of the depth gauge: one for 10° and the other for 20°. It is important to measure the end of the guidewire from the proper side of the depth gauge to accurately assess the guidewire depth within the glenoid vault.

The measurement of the guidewire correlates to the length of central post drill that will be used, as well as the length of the modular central post implant.

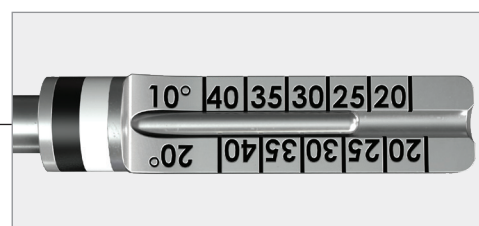

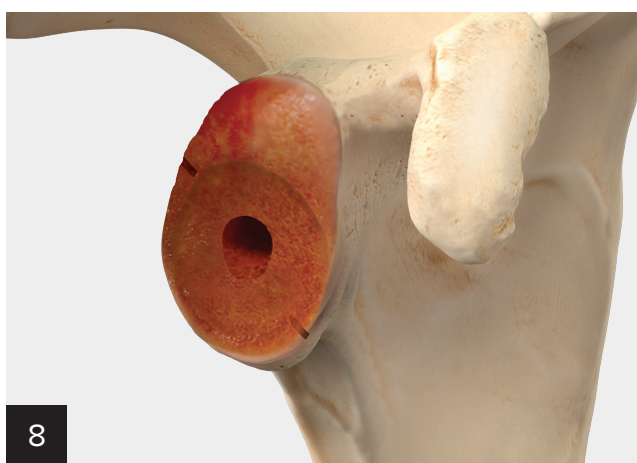
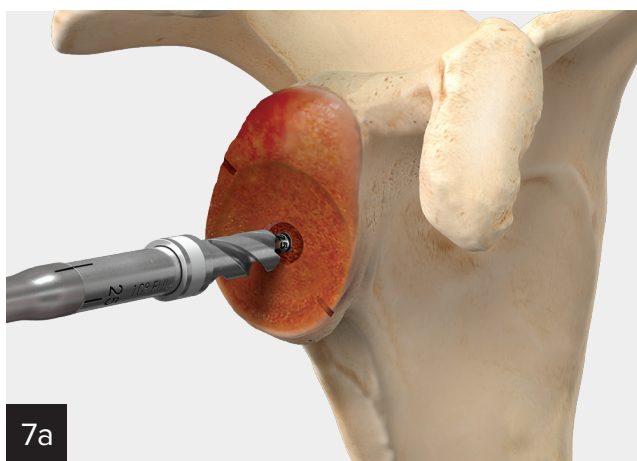

There are two drill caddies in the instrument set for full-wedge baseplates **(a)**: one for 10° (white) and another for 20° (black).

Note: It is important to use the drills corresponding to the selected implant angle to prepare for accurate post depth.

From the drill caddy, select the drill size corresponding to the depth marking noted in the previous step (20 mm, 25 mm, 30 mm, 35 mm, or 40 mm). Attach the selected drill to the modular reamer shaft. Place the drill assembly over the guidewire and advance on power until the collar of the drill is flush with the glenoid face. When drilling is complete, remove the guidewire from the glenoid.

Proceed to Step 11, “Implant Assembly and Insertion” on page 16.

Preparation Steps for Half-Wedge Augments



25° Half-wedge augmented baseplate

Note: The augmented portion of the baseplate may be obliquely oriented or aligned to the peripheral screw holes depending on which implant is chosen. This is an important consideration in planning for the augment orientation.



(a)
Orientation of the oblique augment (a)

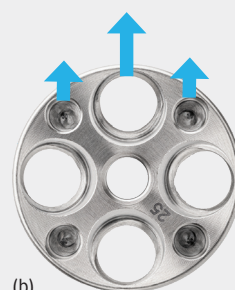

(b)
Orientation of the standard augment (b)

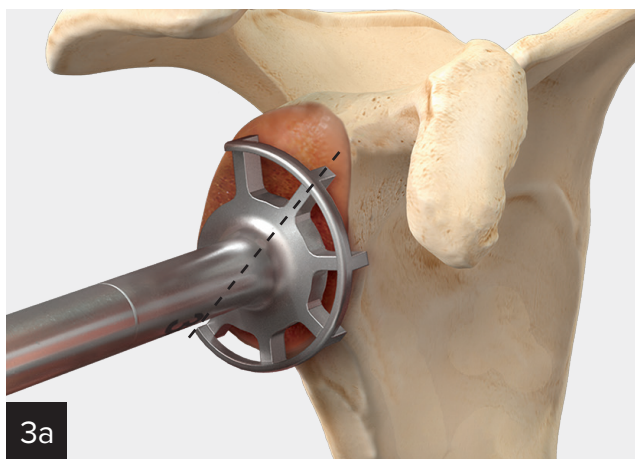

3a

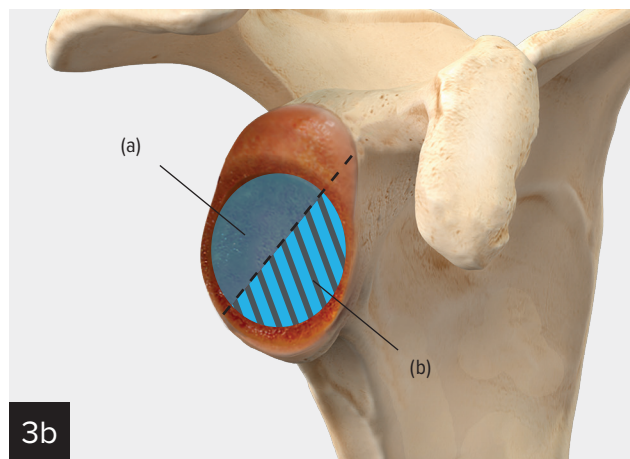

3b

Paleo Glenoid Reaming

Slide the paleo reamer over the guide pin. Ream the glenoid until the anterior/paleo glenoid has been reamed flat within the circumference of the reamer face. The reaming area should be assessed throughout the reaming process, and should stop once the reamed surface extends to the position of the guide pin. This represents the midline between the reamed paleo **(b)** and neo glenoid **(a)** surfaces (see 3b).

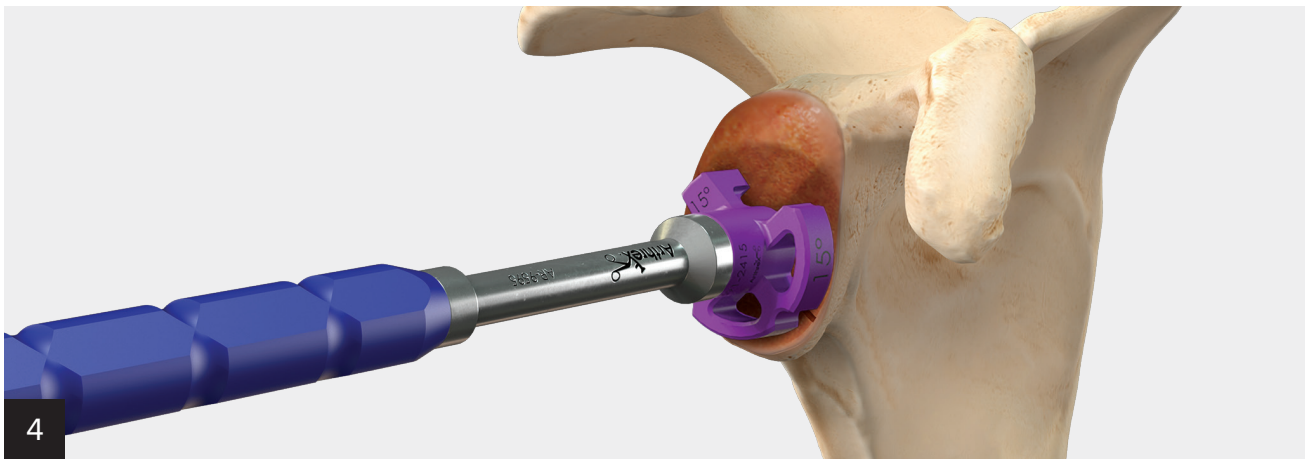

Assessment of Glenoid Defect

Attach the appropriate half-wedge augment sizer onto the modular handle. Each augment sizer is color-coded per augment angle (purple [15° half-wedge]; blue [25° half-wedge]; green [35° half-wedge]). Place the assembly over the guidewire, advancing until the half circle of the sizer rests on the reamed (paleo) glenoid face.

The arm of the sizer should rest where the bony deficit is the greatest. If the arm is unable to touch the glenoid surface within the defect, it may be necessary to evaluate the defect using a sizer with an increased angle.

Once the area containing the greatest bony defect has been identified with the augment sizer, mark the location with a marking pen or electrocautery device. A mark 180° opposite of this location should also be made, as both of these marks are used to assist in orienting the reamer during the glenoid reaming process.

If it is determined that a 35° half-wedge implant is necessary, proceed to step 5. For 15° or 25° implant preparation, proceed to step 6.

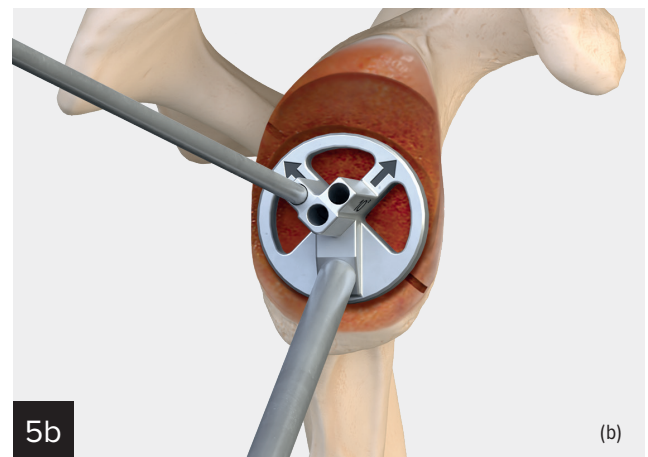
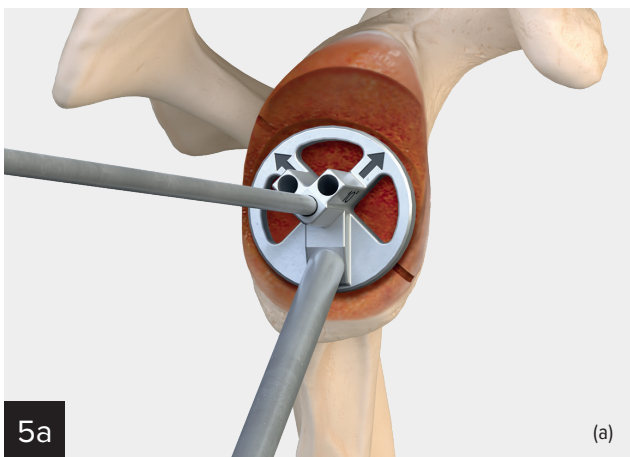

Adjustment of Glenoid Guidewire Placement

Place the center hole of the retroverted pin guide over the 2.8 mm guidewire (a). Rotate guide about the guidewire so that the black arrow on the retroverted pin guide face is aligned to the area of greatest bony defect. Remove the guidewire while continuing to hold the pin guide in place with your other hand. Without moving the guide, place the guidewire into the hole directly beneath the arrow aligned with the bony defect. This hole is 10° divergent from the neutral/central hole (b).

Remove the pin guide, leaving the guidewire in place.

Neo Glenoid Reaming

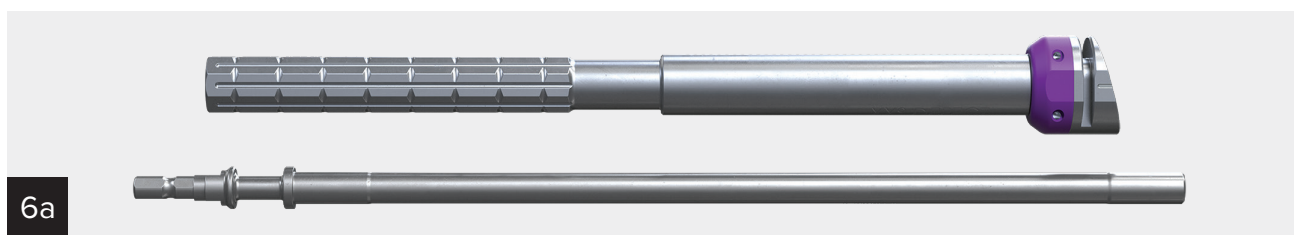

6a

Select the angled reaming sleeve that matches the half-wedge augment sizer used in the previous step. The outer sleeves are color-coded and it is important to verify that the color of the outer sleeve matches the color of the augment sizer.

If using the 35° half-wedge, the 25° reaming sleeve will be used. Verify that you are using the blue outer sleeve that matches the color of the 25° augment sizer.

Note: Refer to the reference chart below for the appropriately sized disposable angled reamer for each Augmented Modular Glenoid System half-wedge implant.

	24 mm	28 mm
15° Half-wedge	S	M
25° Half-wedge	S	L
35° Half-wedge	L	XL

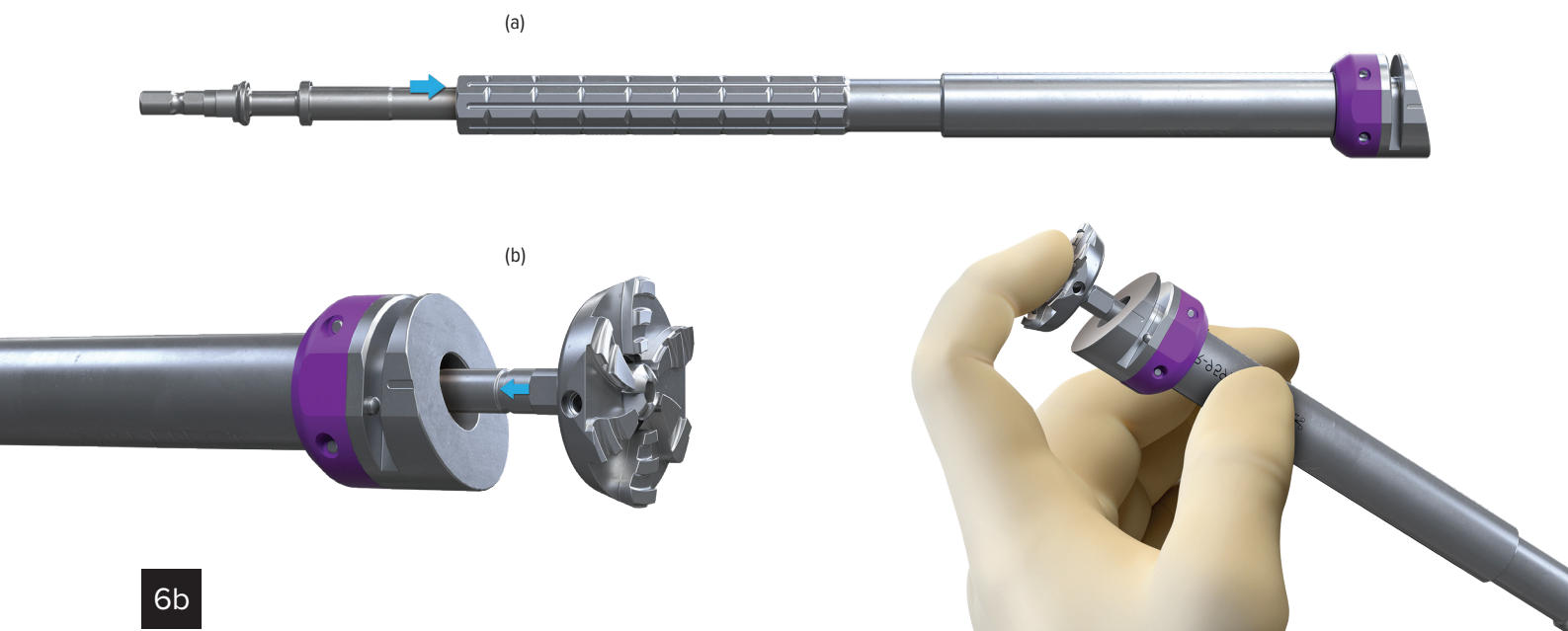

6b

Insert the inner reamer shaft through the angled reamer sleeve **(a)**. Couple the disposable angled reamer to the inner reamer shaft **(b)**. A tactile coupling should be felt.

Insert the half-wedge reaming depth stop into the slots near the face of the angled reamer sleeve. This depth stop prevents overmedializing while reaming the neo glenoid, thus aligning the neo and paleo reamed surface within the center of the glenoid face (see inset image to the right).

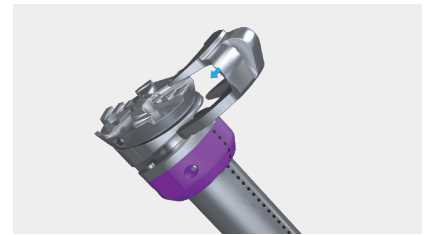

Note: If using the 35° half-wedge, despite using the 25° blue reaming sleeve, ensure that you are using the labeled 35° depth stop.

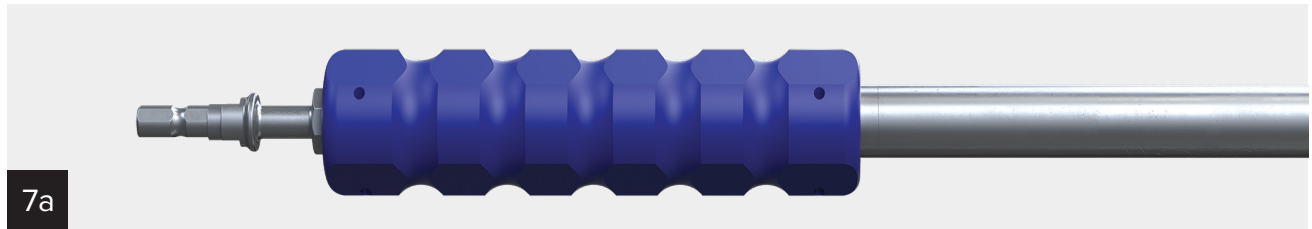

7a

Before attaching the reamer assembly to the powered hand equipment, the orientation sleeve can be added over the angled reamer sleeve to help maintain rotational control while reaming.

Alternatively, the orientation handle can be attached to the angled reamer sleeve. If using the orientation handle, it is recommended to align the handle with the anterior dotted line on the reamer sleeve.

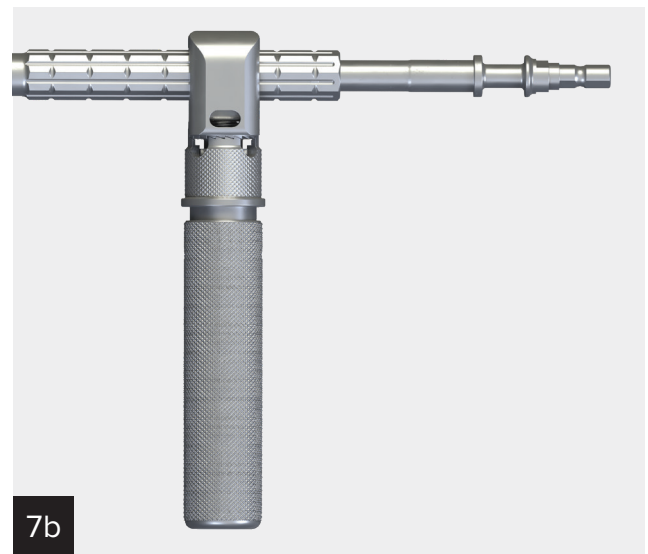

7b

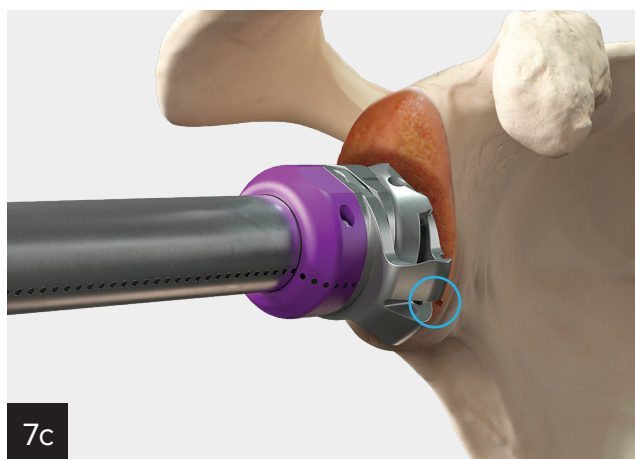

7c

Insert the angled reamer assembly over the guide pin. Rotate the reamer assembly about the pin so that the dotted line on the reamer shaft aligns to the mark opposite of the maximum bony deficit that was previously made. This alignment mark is the best option for maintaining visualization of the reamer orientation while reaming.

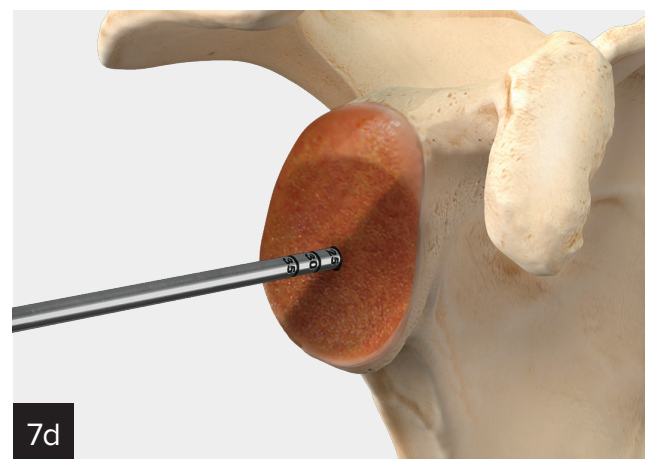

7d

Continue reaming until the depth stop rests within the paleo reamed glenoid face. Make a visual assessment to ensure that the reaming planes from the paleo and neo reaming process align in the center of the glenoid face (the guidewire will mark the point of these converging planes).

Assessment of Reamed Surface

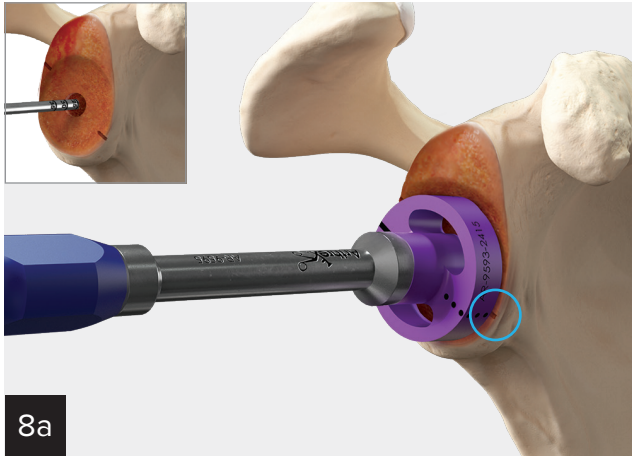

8a

Place the augment trial matching the color and angle of the previously used instrumentation onto the modular handle. Insert the trial assembly over the guidewire and advance until the trial face is seated on the prepared glenoid surface.

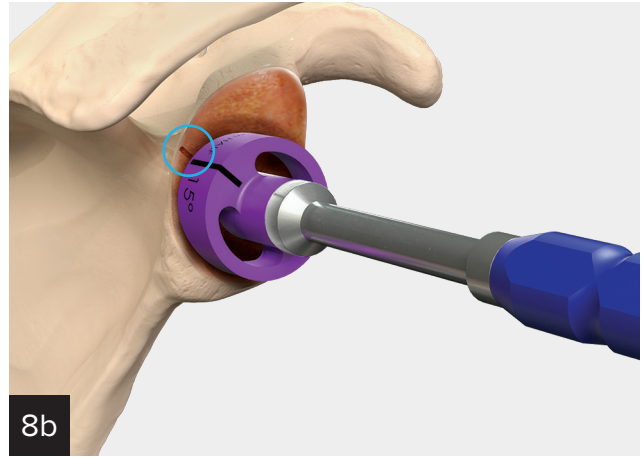

8b

Assess the fit of the trial on the glenoid. To help determine if the trial and prepared glenoid surface made congruent contact, rotate the trial clockwise and counterclockwise. If not, repeat the reaming steps in Step 7 until proper mating of the trial to glenoid surface can be achieved.

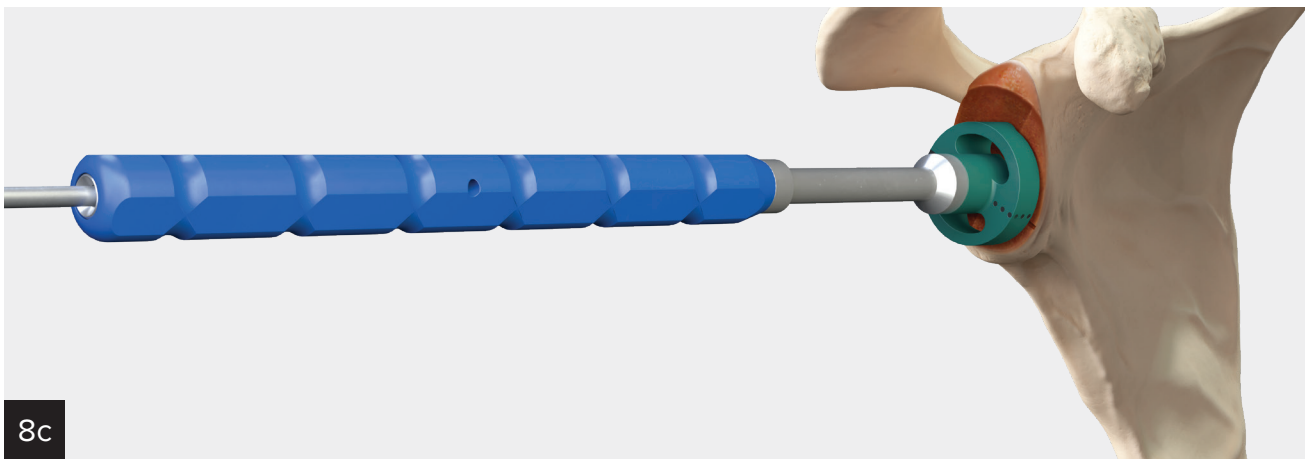

8c

If using a 35° half-wedge augment, remove the guidewire prior to this step. Then using the green 35° trial construct described above, reinsert the guidewire into the original neutral position. If it is determined more reaming is necessary, return to step 5.

Measuring for Central Post Length

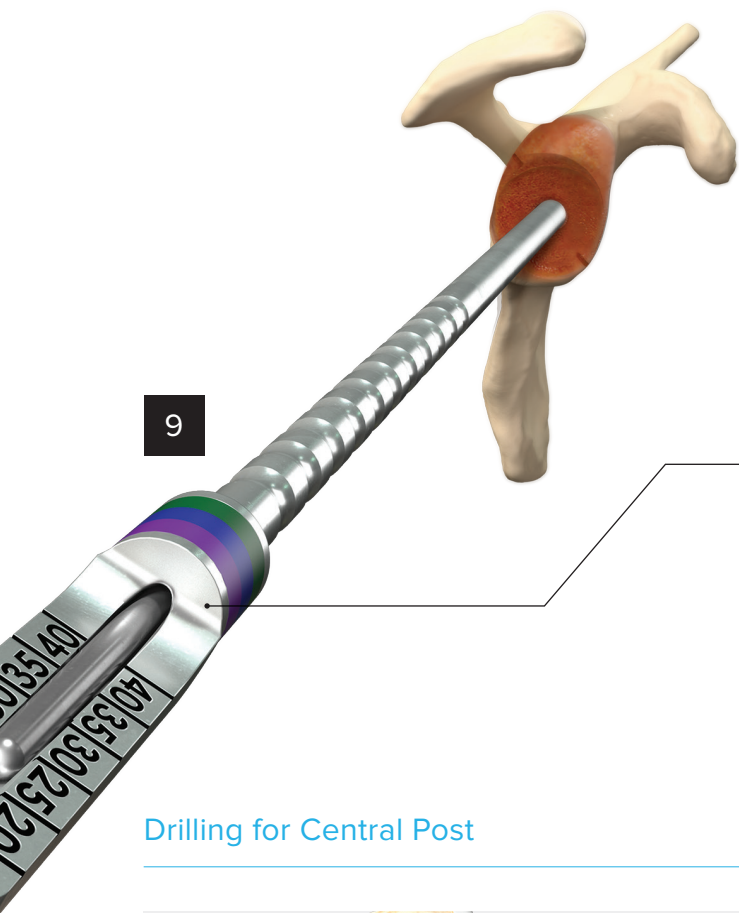

Introduce the half-wedge central post depth gauge over the guidewire.

The measurement of the guidewire correlates to the length of central post drill that will be used, as well as the length of the modular central post implant.



Drilling for Central Post

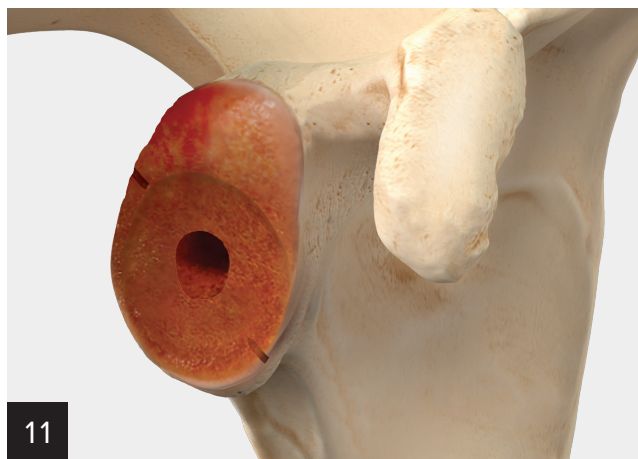
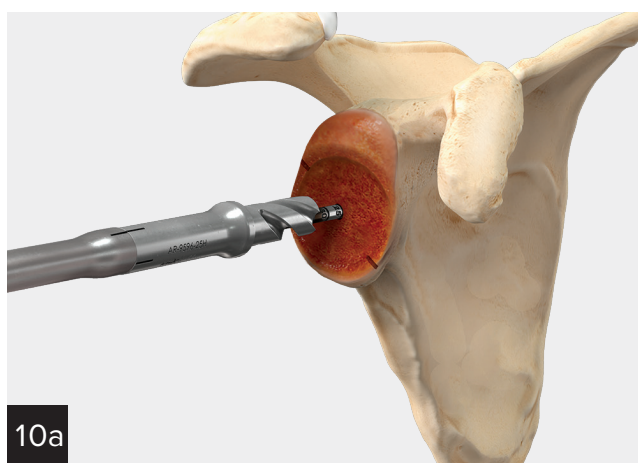

Note: It is important to use the drills corresponding to the selected implant angle to prepare for accurate post depth.

From the drill caddy (a), select the drill size corresponding to the depth marking noted in the previous step (20 mm, 25 mm, 30 mm, 35 mm, or 40 mm). Attach the selected drill to the modular reamer shaft. Place the drill assembly over the guidewire and advance on power until the collar of the drill is flush with the glenoid face. When drilling is complete, remove the guidewire from the glenoid.

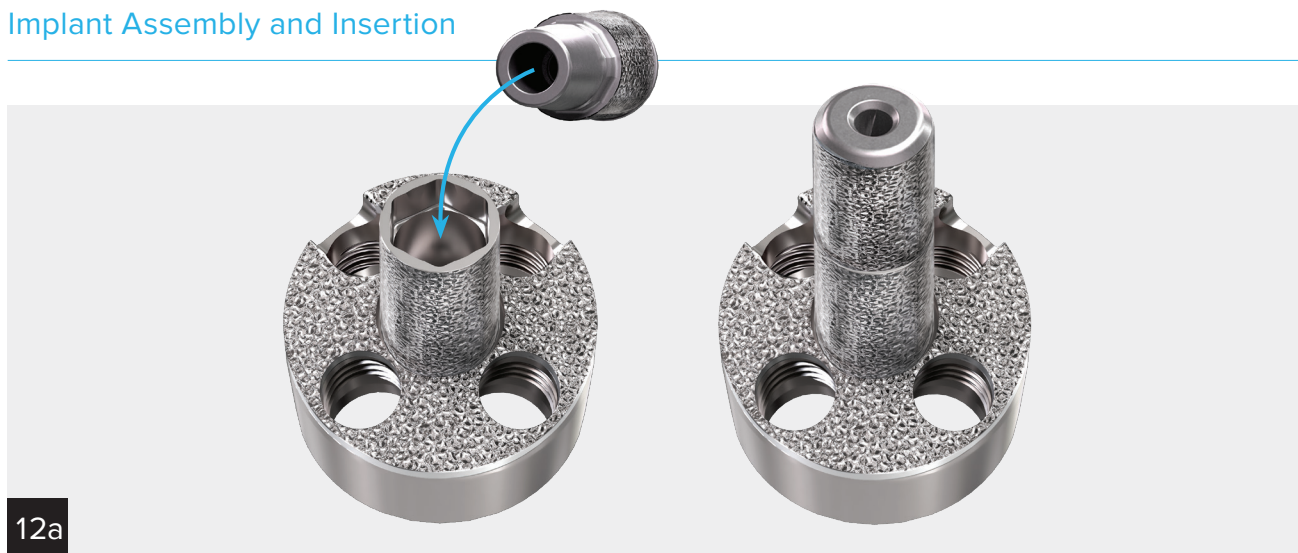

Baseplate Assembly

Combine the modular central post with the augmented modular baseplate component. These components mate via a taper connection. There is a hex feature that must be aligned between the components for the taper to engage. Rotate the components until the hex features align, resulting in a tactile coupling. Place the joined components within the taper assembly stand so that the central post is facing up.

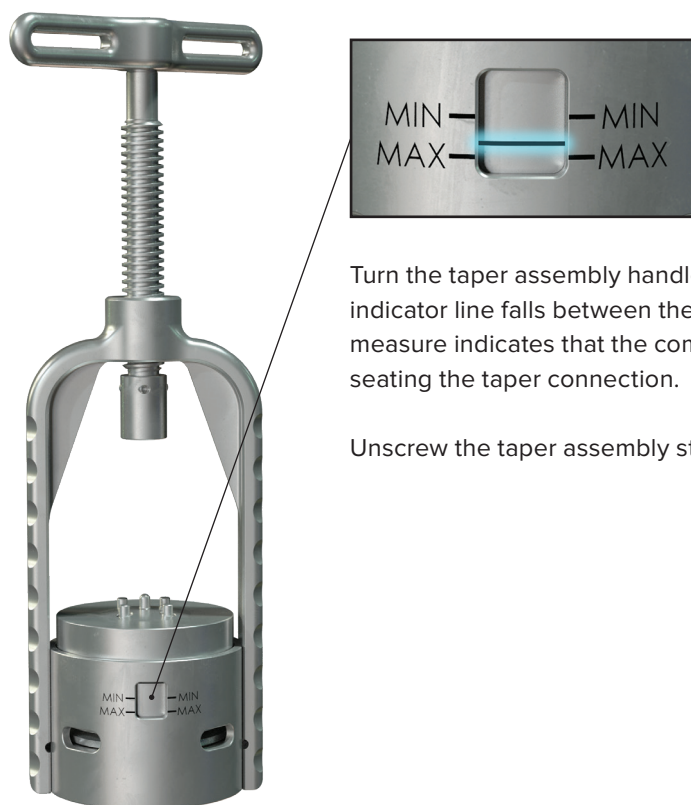

Turn the taper assembly handle, tightening until the taper assembly stand's indicator line falls between the laser lines in the taper assembly window. This measure indicates that the components have been compressed adequately for seating the taper connection.

Unscrew the taper assembly stand and remove the implant.

Baseplate Insertion

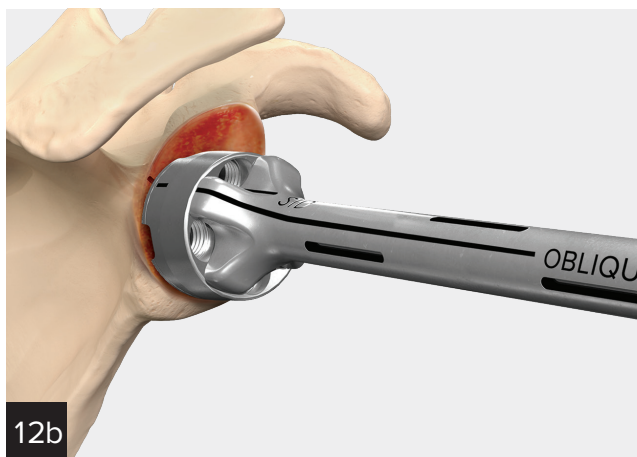

Place the baseplate component(s) onto the threaded inserter/impactor. Take care to align the 4 metal nubs on the threaded inserter/impactor face with the 4 small holes on the periphery of the baseplate face. Further care should be taken to align the appropriate laser marking (OBLIQUE or STD) on the inserter shaft to the solid laser marking of the baseplate augment. Thread the central rod from the threaded inserter/impactor into the baseplate so that the faces of the baseplate and inserter/impactor are flush.

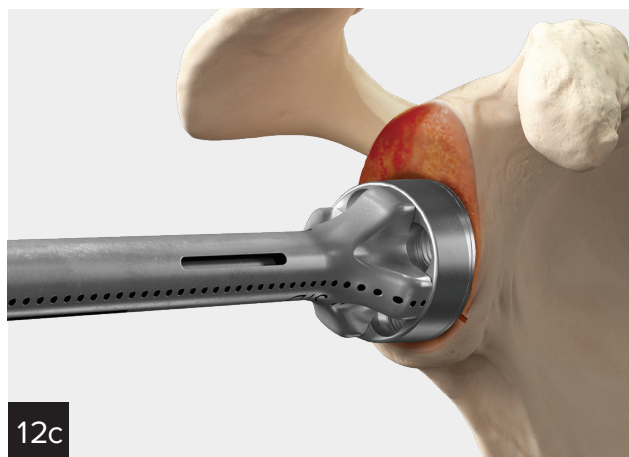

Advance the tip of the central post until it is slightly engaged in the prepared central hole within the glenoid face. Rotate the baseplate until the maximum augmented portion of the baseplate aligns to the electrocautery mark signifying the area of greatest bony deficit. Lightly impact the threaded inserter/impactor with a mallet until the baseplate is fully seated on the glenoid face. Unthread the inserter/impactor from the baseplate and set it aside.

Peripheral Screw Preparation



The peripheral screw holes in the baseplates accept locking or nonlocking screws.

Note: It is recommended that a minimum of 2 peripheral locking screws of at least 24 mm in length be used. For half-wedges, it is recommended that these 2 screws be positioned as closely to the superior and inferior orientation as possible to maximize implant security.

Nonlocking 4.5 mm Screws

Place the nonlocking peripheral screw drill guide in any hole of the baseplate and orient it to the desired screw trajectory. Advance the 3.0 mm drill through the guide, taking note of the depth marks on the drill shaft, which indicate screw length. Alternatively, a depth gauge may be used to determine the peripheral screw length. Repeat the process to prepare for each additional nonlocking screw. Attach the 3.0 mm hex driver to the quick-connect coupling on the ratcheting handle. Ensure that the ratcheting handle is set to "Forward" or "Locked." Place the tip of the hex driver into the selected screw head and insert into the appropriate screw hole within the baseplate. Advance the screw until it is fully seated.

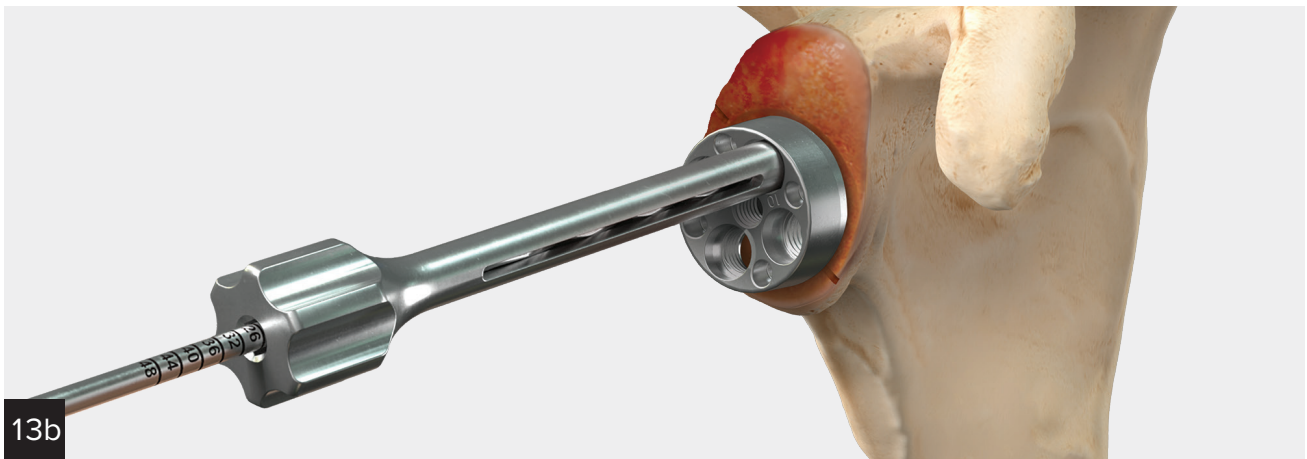

Locking 5.5 mm Screws

Thread the locking peripheral screw drill guide into any screw hole in the baseplate. Advance the 3.0 mm drill through the guide, taking note of the depth marks indicating screw length on the drill shaft. Alternatively, a depth gauge may be used to assess the peripheral screw length. Repeat the process to prepare for each additional locking screw. Attach the 3.0 mm hex driver to the quick-connect coupling on the ratcheting handle. Ensure that the ratcheting handle is set to “Forward” or “Locked.”

Place the tip of the hex driver into the selected screw head and insert into the appropriate screw hole in the baseplate. Advance the screw until it is fully seated.

Note: All screw heads should be slightly recessed relative to the baseplate surface to ensure sufficient clearance for glenosphere seating.

Peripheral Reaming

After the peripheral screws have been inserted, an over-the-baseplate peripheral reamer from the Modular Glenoid System instrument set must be used to ensure that all soft tissue and bone is cleared from around the circumference of the baseplate. This important step confirms that the backside of the glenosphere is free from impingement, which may prevent it from fully seating on the baseplate taper.

The over-the-baseplate taper peripheral reamer should be selected based on the diameter of the augmented baseplate as well as the corresponding glenosphere size. For example, if a 36 mm glenosphere is being used with a 24 mm baseplate, a 36/24 reamer should be selected.

Attach the reamer to the manual driver handle and gently work around the baseplate taper in a rotational fashion, until there is no bony or soft-tissue impingement present.

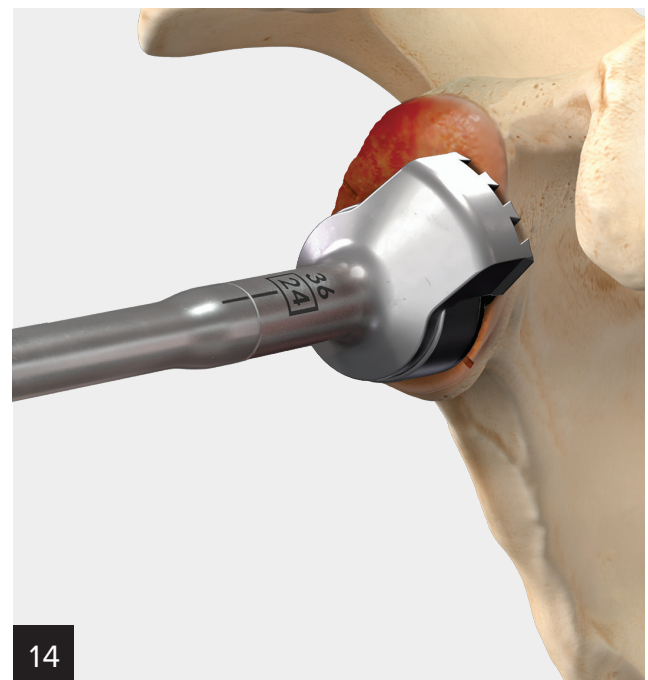

Glenosphere Trialing and Insertion

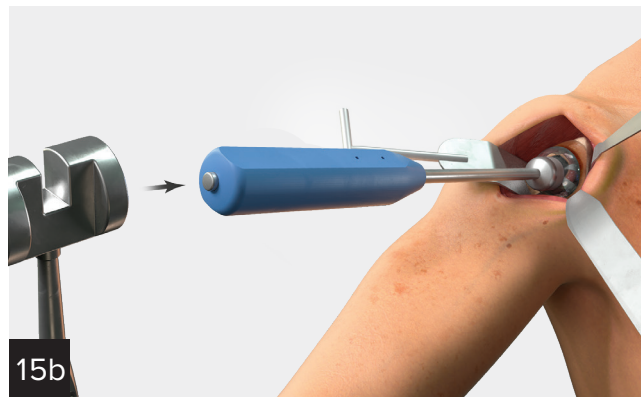
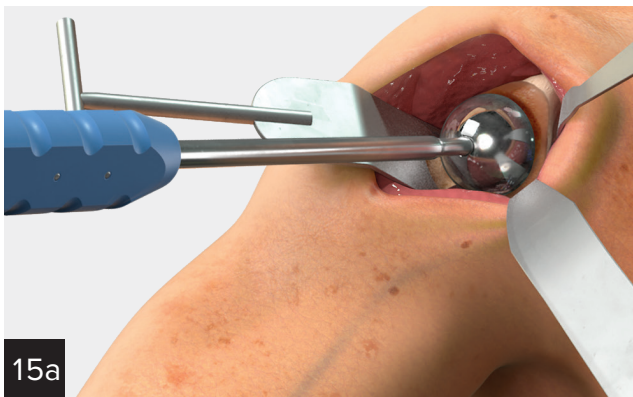

Glenosphere Trialing

Thread the glenosphere trial onto the tip of the glenosphere inserter handle. Place the trial glenosphere onto the baseplate, pressing lightly to seat the taper. Remove the glenosphere inserter handle. To separate the glenosphere trial from the baseplate, thread the glenosphere inserter handle onto the trial and pull gently in an axial fashion to remove it.

Glenosphere Insertion

Attach the glenosphere implant to the glenosphere inserter by threading it fully onto the handle. Introduce the glenosphere onto the baseplate taper, taking care to ensure that the taper is properly aligned. Push the glenosphere onto the baseplate until the taper is aligned/engaged (a). Unscrew the glenosphere inserter from the glenosphere and remove.

With several sharp mallet blows, impact the glenosphere onto the baseplate with the glenosphere/liner impactor (from the humeral instrument tray) (b).

A glenosphere locking screw is packaged with the glenosphere component. Using the modular 3.0 mm hex driver, torque adapter, and ratcheting handle, insert the glenosphere locking screw into the glenosphere hole. Seat the screw fully, ensuring a minimum of 3 N·m of torque is applied to lock the screw.

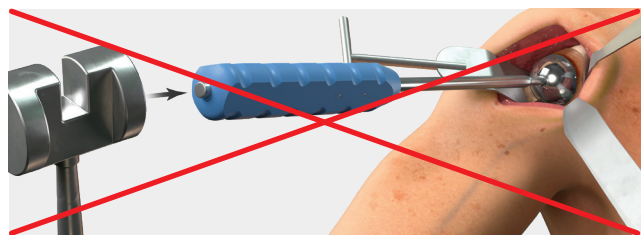

Note: Do not impact the glenosphere onto the baseplate using the glenosphere inserter as this may lead to instrument breakage.

Revision Steps

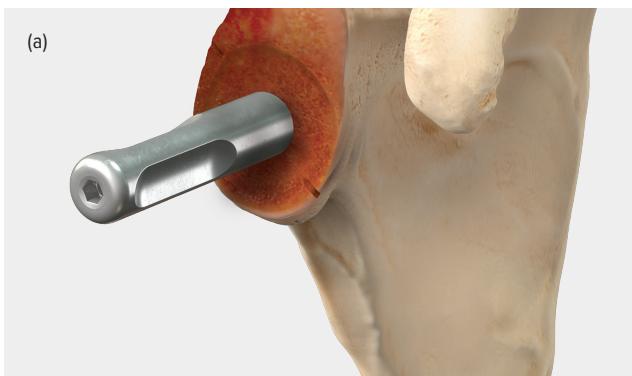

For revision of the Augmented Modular Glenoid System components, please refer to the surgical technique guide for the Modular Glenoid System.

Note: An Augmented MGS-specific trephine adapter is located in the Augmented Modular Glenoid System instrument set and should be used if the modular central post becomes detached from the baseplate during removal (a). All other revision steps are identical to those described within the nonaugmented MGS surgical technique.

Ordering Information - Instrument Tray (Top Level)

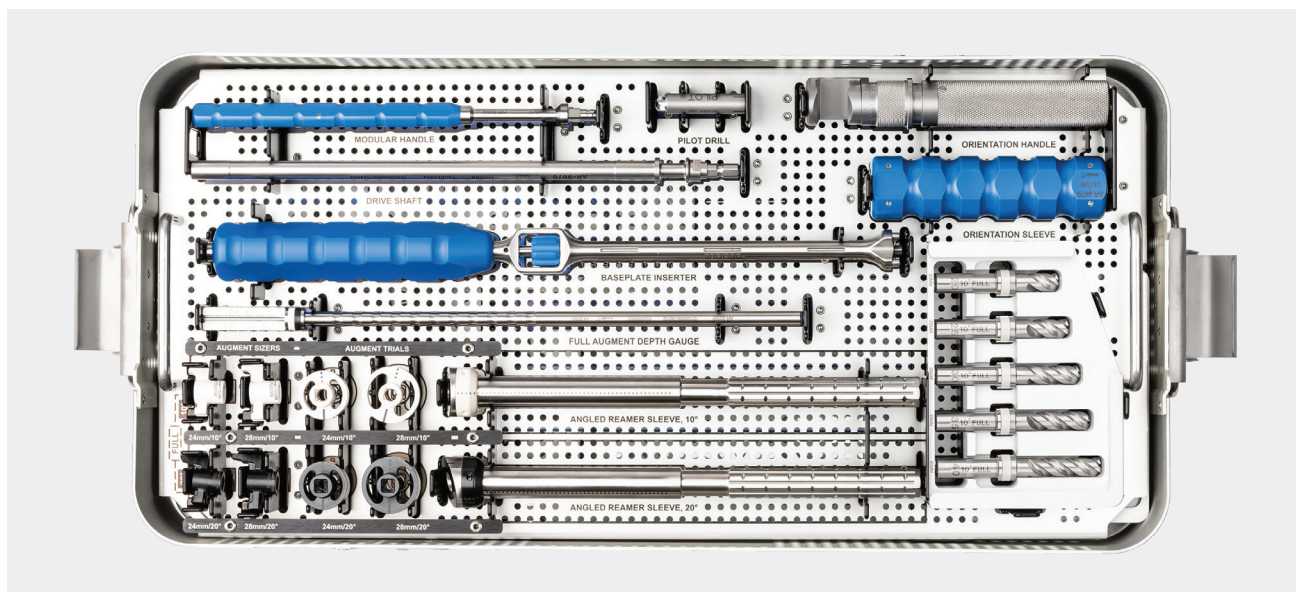

Instruments

Product Description	Item Number
24 mm Baseplate, 10° full-wedge augment sizer	AR-9592-2410
24 mm Baseplate, 20° full-wedge augment sizer	AR-9592-2420
28 mm Baseplate, 10° full-wedge augment sizer	AR-9592-2810
28 mm Baseplate, 20° full-wedge augment sizer	AR-9592-2820
24 mm Baseplate, 10° full-wedge augment trial	AR-9594-2410
24 mm Baseplate, 20° full-wedge augment trial	AR-9594-2420
28 mm Baseplate, 10° full-wedge augment trial	AR-9594-2810
28 mm Baseplate, 20° full-wedge augment trial	AR-9594-2820
Modular Handle	AR-9595
Modular Drills, 10° full, 20 mm	AR-9596-1020F
Modular Drills, 10° full, 25 mm	AR-9596-1025F
Modular Drills, 10° full, 30 mm	AR-9596-1030F
Modular Drills, 10° full, 35 mm	AR-9596-1035F
Modular Drills, 10° full, 40 mm	AR-9596-1040F
Modular Drills, 20° full, 20 mm	AR-9596-2020F
Modular Drills, 20° full, 25 mm	AR-9596-2025F
Modular Drills, 20° full, 30 mm	AR-9596-2030F
Modular Drills, 20° full, 35 mm	AR-9596-2035F
Modular Drills, 20° full, 40 mm	AR-9596-2040F
Angled Reamer Sleeve, 10°	AR-9597-10
Angled Reamer Sleeve, 20°	AR-9597-20
Full-Wedge Augment Depth Gauge	AR-9599F
Baseplate Inserter	AR-9623-A
Augmented Trepine Adapter	AR-9661-A
Pilot Drill	AR-9596-P
10° Drill Caddy	AR-9579C-DC10FA
20° Drill Caddy	AR-9579C-DC20FA

Augmented Instrument Case

Product Description	Item Number
Implant Set	AR-9579SI
Implant Set, loaner	RAR-9579SI
Instrument Set	AR-9579S
Instrument Set, loaner	RAR-9579S

Ordering Information - Instrument Tray (Bottom Level)

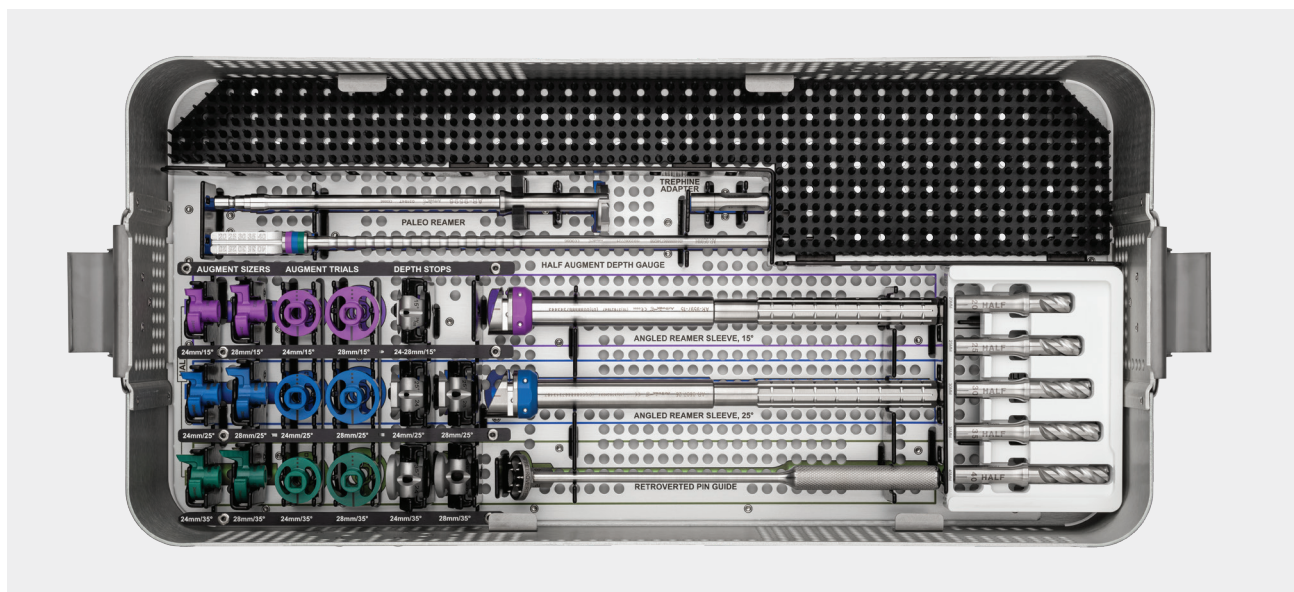

Instruments

Product Description	Item Number
Paleo Reamer	AR-9596
Trephine Adapter	AR-9661-A
Half Augment Depth Gauge	AR-9599H
24 mm Baseplate, 15° half-wedge augment sizer	AR-9591-2415
24 mm Baseplate, 25° half-wedge augment sizer	AR-9591-2425
24 mm Baseplate, 35° half-wedge augment sizer	AR-9591-2435
28 mm Baseplate, 15° half-wedge augment sizer	AR-9591-2815
28 mm Baseplate, 25° half-wedge augment sizer	AR-9591-2825
28 mm Baseplate, 35° half-wedge augment sizer	AR-9591-2835
24 mm Baseplate, 15° half-wedge augment trial	AR-9593-2415
24 mm Baseplate, 25° half-wedge augment trial	AR-9593-2425
24 mm Baseplate, 35° half-wedge augment trial	AR-9593-2435
28 mm Baseplate, 15° half-wedge augment trial	AR-9593-2815
28 mm Baseplate, 25° half-wedge augment trial	AR-9593-2825
28 mm Baseplate, 35° half-wedge augment trial	AR-9593-2835
20 mm Modular Drills, half	AR-9596-20H
25 mm Modular Drills, half	AR-9596-25H
30 mm Modular Drills, half	AR-9596-30H
35 mm Modular Drills, half	AR-9596-35H
40 mm Modular Drills, half	AR-9596-40H
Angled Reamer Sleeve, 15°	AR-9597-15
Angled Reamer Sleeve, 25°	AR-9597-25
Retroverted Pin Guide	AR-9680

Product Description	Item Number
24 mm Depth Stop, 15°	AR-9598-15
24 mm Depth Stop, 25°	AR-9598-2425
28 mm Depth Stop, 25°	AR-9598-2825
24 mm Depth Stop, 35°	AR-9598-2435
28 mm Depth Stop, 35°	AR-9598-2835
Half Drill Caddy	AR-9579C-DCHA

Ordering Information

Augmented Modular Glenoid System Full-Wedge Implants

Implants

Product Description	Item Number
24 mm Baseplate, 10° full-wedge augment, oblique	AR-9580-2410
24 mm Baseplate, 20° full-wedge augment, oblique	AR-9580-2420
24 mm Baseplate, 10° full-wedge augment, +2 lateralized, oblique	AR-9580-2410-2
24 mm Baseplate, 20° full-wedge augment, +2 lateralized, oblique	AR-9580-2420-2
24 mm Baseplate, 10° full-wedge augment	AR-9580-2410S
24 mm Baseplate, 20° full-wedge augment	AR-9580-2420S
24 mm Baseplate, 10° full-wedge augment, +2 lateralized	AR-9580-2410-2S
24 mm Baseplate, 20° full-wedge augment, +2 lateralized	AR-9580-2420-2S
28 mm Baseplate, 10° full-wedge, oblique	AR-9580-2810
28 mm Baseplate, 20° full-wedge, oblique	AR-9580-2820
28 mm Baseplate, 10° full-wedge, +2 lateralized, oblique	AR-9580-2810-2
28 mm Baseplate, 20° full-wedge, +2 lateralized, oblique	AR-9580-2820-2
28 mm Baseplate, 10° full-wedge	AR-9580-2810S
28 mm Baseplate, 20° full-wedge	AR-9580-2820S
28 mm Baseplate, 10° full-wedge, +2 lateralized	AR-9580-2810-2S
28 mm Baseplate, 20° full-wedge, +2 lateralized	AR-9580-2820-2S

Augmented Modular Glenoid System Half-Wedge Implants

Implants

Product Description	Item Number
24 mm Baseplate, 15° half-wedge augment, oblique	AR-9581-2415
24 mm Baseplate, 25° half-wedge augment, oblique	AR-9581-2425
24 mm Baseplate, 35° half-wedge augment, oblique	AR-9581-2435
24 mm Baseplate, 15° half-wedge augment, +2 lateralized, oblique	AR-9581-2415-2
24 mm Baseplate, 25° half-wedge augment, +2 lateralized, oblique	AR-9581-2425-2
24 mm Baseplate, 35° half-wedge augment, +2 lateralized, oblique	AR-9581-2435-2
24 mm Baseplate, 15° half-wedge augment	AR-9581-2415S
24 mm Baseplate, 25° half-wedge augment	AR-9581-2425S
24 mm Baseplate, 35° half-wedge augment	AR-9581-2435S
24 mm Baseplate, 15° half-wedge augment, +2 lateralized	AR-9581-2415-2S
24 mm Baseplate, 25° half-wedge augment, +2 lateralized	AR-9581-2425-2S
24 mm Baseplate, 35° half-wedge augment, +2 lateralized	AR-9581-2435-2S
28 mm Baseplate, 15° half-wedge, oblique	AR-9581-2815
28 mm Baseplate, 25° half-wedge, oblique	AR-9581-2825
28 mm Baseplate, 35° half-wedge, oblique	AR-9581-2835
28 mm Baseplate, 15° half-wedge, +2 lateralized, oblique	AR-9581-2815-2
28 mm Baseplate, 25° half-wedge, +2 lateralized, oblique	AR-9581-2825-2
28 mm Baseplate, 35° half-wedge, +2 lateralized, oblique	AR-9581-2835-2
28 mm Baseplate, 15° half-wedge	AR-9581-2815S
28 mm Baseplate, 25° half-wedge	AR-9581-2825S
28 mm Baseplate, 35° half-wedge	AR-9581-2835S
28 mm Baseplate, 15° half-wedge, +2 lateralized	AR-9581-2815-2S
28 mm Baseplate, 25° half-wedge, +2 lateralized	AR-9581-2825-2S
28 mm Baseplate, 35° half-wedge, +2 lateralized	AR-9581-2835-2S

Modular Posts

Product Description	Item Number
Modular Post, 20 mm	AR-9582-20
Modular Post, 25 mm	AR-9582-25
Modular Post, 30 mm	AR-9582-30
Modular Post, 35 mm	AR-9582-35
Modular Post, 40 mm	AR-9582-40

Disposables

Product Description	Item Number
Angled Reamer, small	AR-9675-S
Angled Reamer, medium	AR-9675-M
Angled Reamer, large	AR-9675-L
Angled Reamer, extra large	AR-9675-XL
3.0 mm Drill	AR-9628S

Modular Glenoid System: Key Dimensions

Full-Wedge Implants

Implant Description	A	B	C	D
24 mm Baseplate, 10° full-wedge	10°	4.2 mm	8 mm	24 mm
24 mm Baseplate, 20° full-wedge	20°	8.7 mm	8 mm	24 mm
24 mm Baseplate, 10° full-wedge, +2 lateralized	10°	4.2 mm	10 mm	24 mm
24 mm Baseplate, 20° full-wedge, +2 lateralized	20°	8.7 mm	10 mm	24 mm
28 mm Baseplate, 10° full-wedge	10°	4.9 mm	8 mm	28 mm
28 mm Baseplate, 20° full-wedge	20°	10.2 mm	8 mm	28 mm
28 mm Baseplate, 10° full-wedge, +2 lateralized	10°	4.9 mm	10 mm	28 mm
28 mm Baseplate, 20° full-wedge, +2 lateralized	20°	10.2 mm	10 mm	28 mm

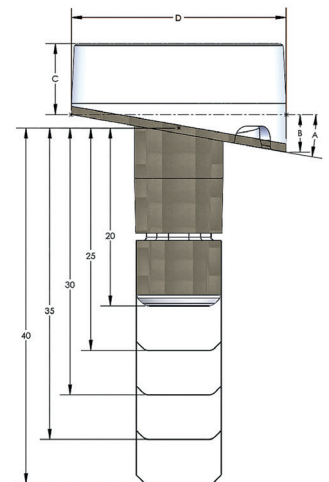

Half-Wedge Implants

Implant Description	A	B	C	D
24 mm Baseplate, 15° half-wedge	15°	3.2 mm	8 mm	24 mm
24 mm Baseplate, 25° half-wedge	25°	5.6 mm	8 mm	24 mm
24 mm Baseplate, 35° half-wedge	35°	8.4 mm	8 mm	24 mm
24 mm Baseplate, 15° half-wedge, +2 lateralized	15°	3.2 mm	10 mm	24 mm
24 mm Baseplate, 25° half-wedge, +2 lateralized	25°	5.6 mm	10 mm	24 mm
24 mm Baseplate, 35° half-wedge, +2 lateralized	35°	8.4 mm	10 mm	24 mm
28 mm Baseplate, 15° half-wedge	15°	3.8 mm	8 mm	28 mm
28 mm Baseplate, 25° half-wedge	25°	6.5 mm	8 mm	28 mm
28 mm Baseplate, 35° half-wedge	35°	9.8 mm	8 mm	28 mm
28 mm Baseplate, 15° half-wedge, +2 lateralized	15°	3.8 mm	10 mm	28 mm
28 mm Baseplate, 25° half-wedge, +2 lateralized	25°	6.5 mm	10 mm	28 mm
28 mm Baseplate, 35° half-wedge, +2 lateralized	35°	9.8 mm	10 mm	28 mm

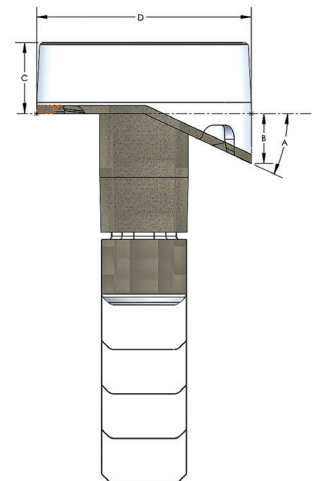



This description of technique is provided as an educational tool and clinical aid to assist properly licensed medical professionals in the usage of specific Arthrex products. As part of this professional usage, the medical professional must use their professional judgment in making any final determinations in product usage and technique. In doing so, the medical professional should rely on their own training and experience, and should conduct a thorough review of pertinent medical literature and the product's directions for use. Postoperative management is patient-specific and dependent on the treating professional's assessment. Individual results will vary and not all patients will experience the same postoperative activity level and/or outcomes.

arthrex.com

© 2024-01 Arthrex Inc. All rights reserved. LT1-000169-en-US_H



Arthrex manufacturer,
authorized representative,
and importer information
(Arthrex eIFUs)



US patent information